



Combination Meter



Rear Window D

2 3 4 5 6

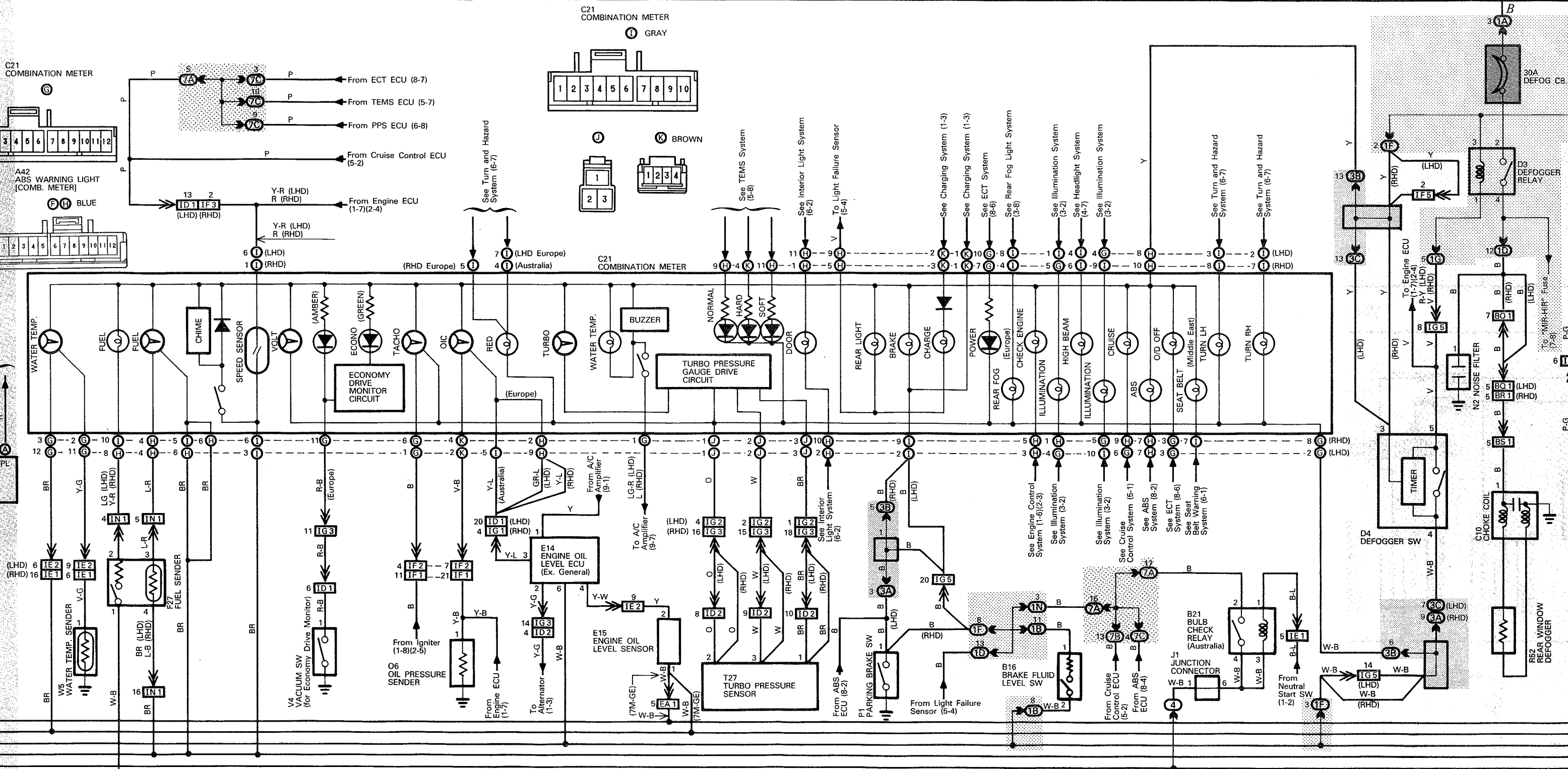

TE = Located on left kick panel (LHD) = Angebracht am linken Seitenblech des Vorderen Fußraums
 = Located on right kick panel (RHD) = Angebracht am rechten Seitenblech des Vorderen Fußraums
 = Monté sur tôle de pied de caisse gauche = Situado en el panel apoyapiés izquierdo
 = Monté sur la tôle de pied de caisse droite = Situado en el panel apoyapiés derecho
 IF = Located on instrument panel center = Monté sous derrière l'autoradio
 = Located on back panel center = Monté sous le panneau arrière
 = an Schraube Nr. 4 des Relaiskastens = Angebracht an der Innenseite der hinteren Wand des Relaiskastens
 = Ubicado en el perno de fijación del bloque de relevadores No. 4 = Situado en el panel posterior